

B 300

MANUAL



CONTENTS

Contents	page 1
Preface	page 2
The B300 presents itself	page 3
Control and Display	pages 4-6
Test of mechanical watches	page 7
Test of quartz crystal watches (LCD)	page 8
Test of quartz crystal watches (analog type)	page 9
Alphanumeric print	page 10
Insert paper roll	page 11
Change ink roll cassette	page 12
Technical data	page 13
Computer connection (RS - 232)	page 14
Help	page 15

PREFACE

**You are the proud owner of a B 300 .
Congratulations, you made the right choice.**

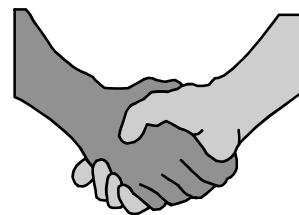

You probably know that Greiner vibrograf has a long standing tradition in the manufacture of watch timing devices.

A very important factor is the tremendous development, the electronic field went through. A multitude of new components, miniaturization, new technologies and automatisations demanded the continuous adaptation of the present testing machines.

We believe the B 300 presents an electronic apparatus that not only contains the "State of the Art" in electronics but also a combination of principles which formerly could only be realized by several individual machines.

The B 300 allows to test practically all existing watches!

The measured parameters can be recorded visually, printed by the recording mechanism or displayed on a computer screen.

The design consumes very little benchspace, has very low noise emission and is easy to read.

Completely new realized demands on the accuracy of the time standard allow to measure the perfection of timing obtained with quartz crystal controlled watches. Just imagine that accuracy in the range of 10^{-8} are the values, figures that are a couple of magnitudes better than the earth rotation!

Assuming that you selected the B 300, proves to us that we are on the right track with our development. The excellent quality of the apparatus will serve you the best !
Let us briefly familiarize you with the many possibilities.

This manual is thought of being a guide to navigate you through the use, maintenance and interpretation of the results.

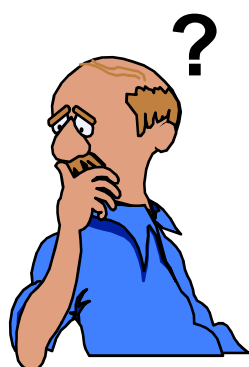

Should you still have any questions,
please call us directly or one of our service agencies.

Greiner vibrograf AG
Mittelstrasse 2
CH - 4900 LANGENTHAL

TEL. ++41 62 923 44 33
Fax. ++ 41 62 923 18 46

THE B 300 PRESENTS ITSELF

Front-view

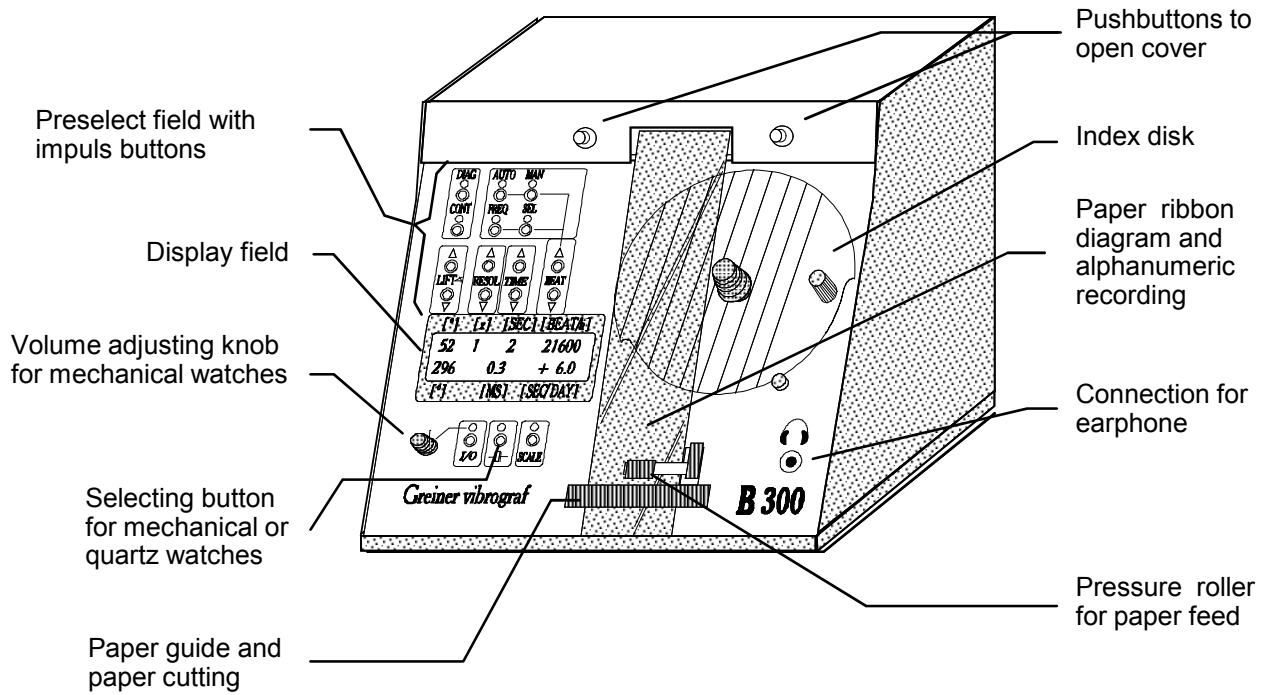

Back view

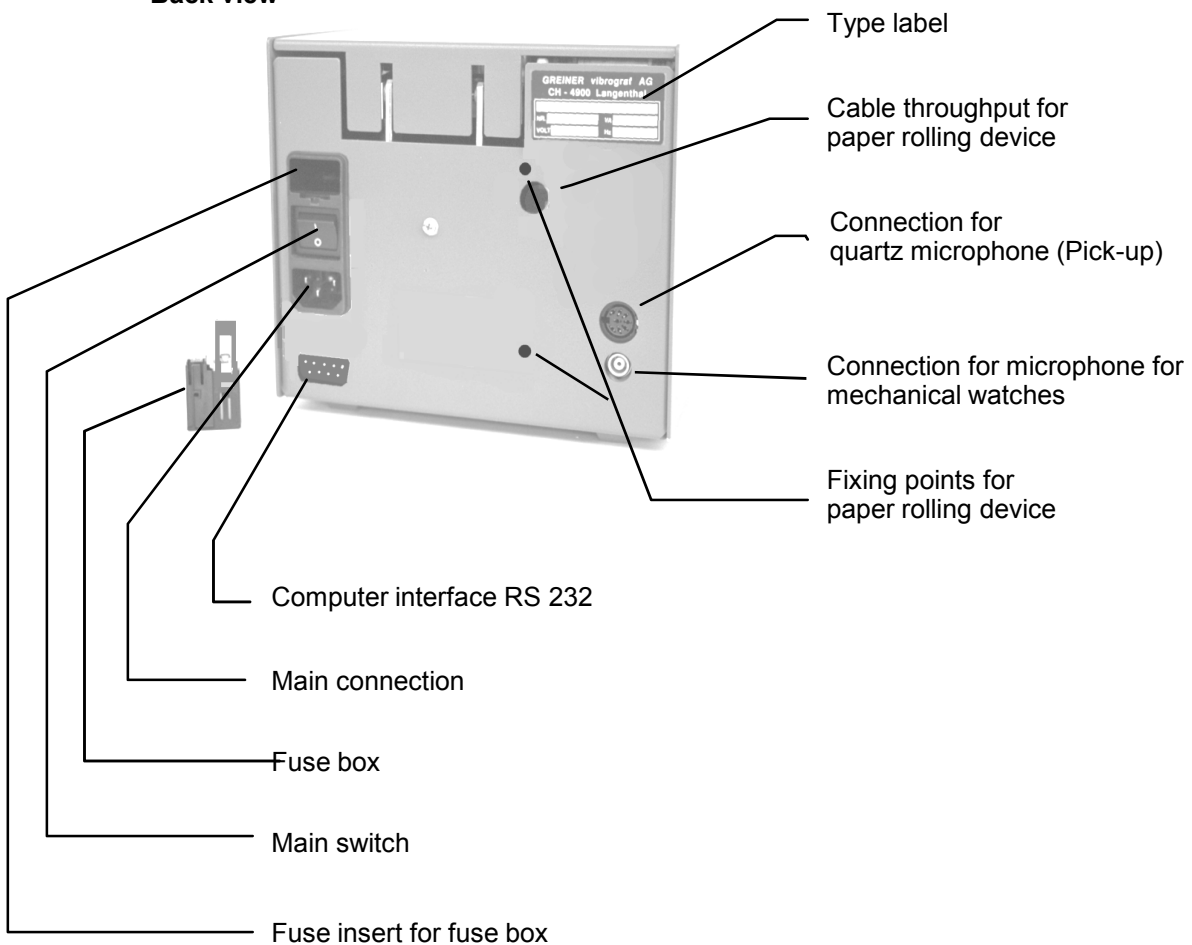

CONTROL AND DISPLAY

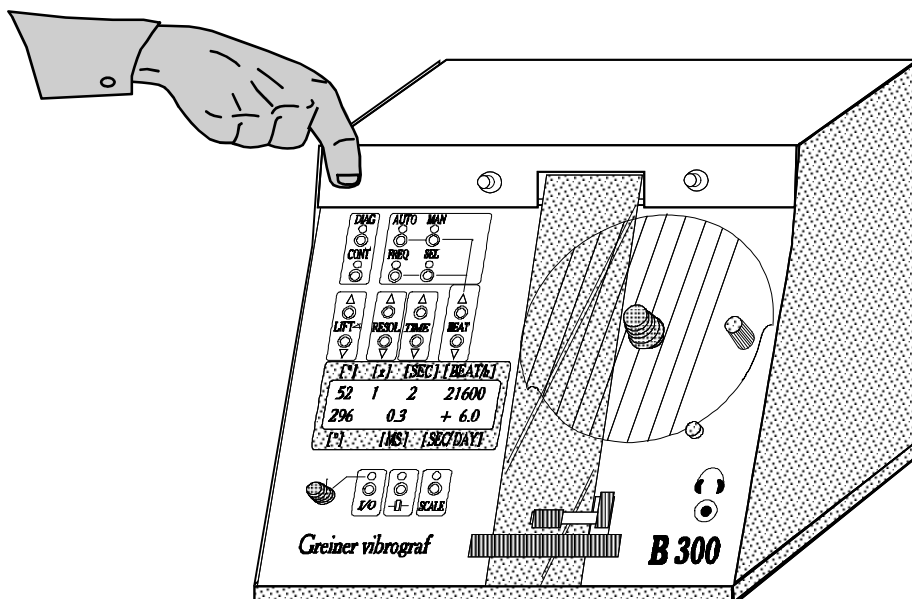

DIAG Recording on paper ON / OFF

- The light is on for activated recording
- The paper advance starts automatically as soon as a watch signal is detected.
- The paper advance stops if no watch signal is detected (machine standby).

CONT This button has 2 functions

- Short push ON / short push OFF : Continuous recording of the measured values and continuous paper advance
- Push and hold: Amplitude, Repère and Beat deviation are printed alphanumerically.

AUTO Automatic beat selection

- The light is on for activated beat selection.
- The beat of the watch is selected, displayed and locked in.

MAN Manual beat selection

- The light is on if manual beat selection is in service.
- The desired standard beat can be adjusted between 3600 and 36000.
(Standard beat list see page 13)

Note: We use the french word " Repère " to indicate the value in ms (milliseconds) a watch or clock is "not in beat", as it is known a watch or clock to limp. The french word seems to be traditionally the best term to describe this failure of adjustment.

CONTROL AND DISPLAY

FREQ Measured beat

- If the button is pushed, the currently measured beat is registered to indicate the beat deviation from zero
- The recording locks now into this frequency and the recording is a straight line.
- Push again makes a reset and the new current beat is registered again.
- The light is on if a beat frequency is locked in.
- The indicated beat can be changed by pushing SEL and then adjusted to the desired value by pushing the beat button up or down.
- Short push, changes beat by beat. Push and hold, changes beat value fast.

SEL Takes over measured beat

- The indicated beat measured by AUTO, MAN, or FREQ. can be taken over by activating SEL and adjusted between 3590 and 36100 by pushing the beat button up or down.
- Short push, changes beat by beat. Push and hold, changes beat value fast.

LIFT Selection of lift angle

- By the buttons up or down, the lift angle can be adjusted between 30 and 70 degrees.
- It is displayed in angular degrees (°).
- Short push, changes degree by degree. Push and hold, changes degree value fast.

RESOL Resolution of the printed recording

- By the buttons up or down, the resolution of scale factor can be changed between 0,5 and 50.
- IMPORTANT: 0,5 corresponds with resolution by factor 1
- 50 corresponds with resolution by factor 100 (List see page 13)

TIME Measuring time

- By the buttons up or down, the measuring time interval can be adjusted between 2 and 60 sec.
- The results of Amplitude and Repère are displayed after 2 seconds.
- The result of beat deviation is displayed the first time after the countdown of the selected measuring time interval and then again every 2 seconds.

BEAT Beat selection

- By the buttons up or down, the beat frequency can be adjusted between 3590 and 36100
- These buttons are only effective if MAN or SEL are active.
- Short push, changes beat by beat. Push and hold, changes beat value fast and continuously.
- The selected Beat is displayed as Beat / h



Volume adjusting for mechanical watches

- The watch beat reception is visible on the green LED beside the button.
- Volume increase: clockwise rotation. This includes volume in the earphone.
- Standard setting on vertical line

I / 0 Preselect line on display ON / OFF

- The preselect line (upper display line) ON / OFF

CONTROL AND DISPLAY



Selection of microphone

- Lamp ON = Microphone (Pick- up) for Quartz crystal watch is active.
- Lamp OFF = Microphone for mechanical watch is active.

SCALE Selection of indication in display field [SEC/DAY]

- Lamp ON = Display of electronically calculated beat deviation in the field.
- Lamp OFF = Display of value adjusted by the index scale in the field.

DISPLAY Divided into 2 lines

- Upper line = Preselection values
- Lower line = indication of the measured values Amplitude , Repère, Beat deviation

Upper line	[°]	Degrees of lift angle 30 - 70 °
	[x]	Display of scale factor 0,5 - 50
	[SEC]	Measure time interval 2 - 60 sec.
	[BEAT/h]	Display of selected beat 3590 - 36100

Lower line

[°]	Display of amplitude (mechanical watches only)
[MS]	Display of repère (mechanical watches only) milliseconds
[SEC/DAY]	Display of beat deviation for mechanical and Quartz crystal watches



Receptacle for ear phone

TEST OF MECHANICAL WATCHES

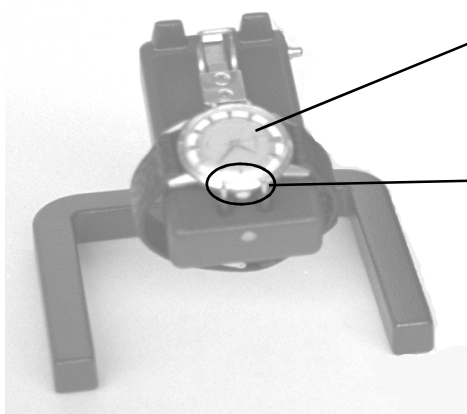

Watch to be tested

Make sure the watch casing or the winding crown touches the active fork.
Only this guarantees proper recording of the signals.

Preset the machine for recording mechanical watches () lamp OFF

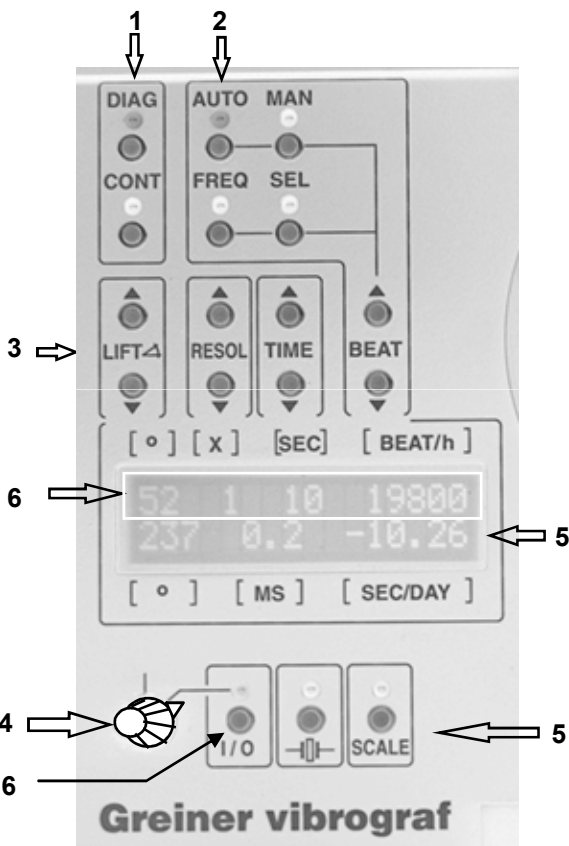

1. The beats are recorded on the paper if the button **DIAG** is activated.
2. Push **AUTO** for automatic beat.
3. Adjust lift angle. (Most standard watches use 52°).
4. If the watch signals come out weak, turn volume control knob clockwise to increase amplification until the light blinks at **I/O**.

Note: As soon as the apparatus receives a correct signal, it calculates the beat and selects the closest standard beat rate. (See standard beat list page xx). It locks then onto this beat and starts displaying the beat with the deviation.

6. By pushing the button **I/O** the preselect (upper display line) can be faded out.
7. The resolution on the paper can be selected by changing the value **[X]**. (See page xx for stored values.)
8. The measuring time interval can be selected by changing the value **[SEC]**. (See page xx for stored values.)

5. Value of the beat deviation (SEC/DAY) by adjusting the index scale onto the recorded dot line on the paper.

To measure the beat deviation in this mode, the light **Scale** has to be ON. Otherwise the calculated value will be on the display no matter where the index scale stands.

TEST OF QUARTZ CRYSTAL WATCHES (LCD)

General :

Most of the analog quartz watches with stepper motor can be recorded acoustically on a microphone for mechanical watches (MP 86 or other) as well as on the Pick-up microphone for quartz crystal watches.

With microphone for mechanical watch, follow instructions on page 7 .

With electronic Pick-up, follow instructions on page 9

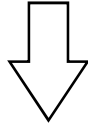
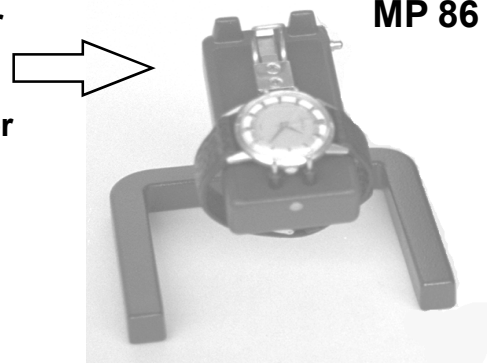

Pick - up



Test and record a quartz crystal LCD watch by electronic Pick - up microphone

Preset the machine for recording quartz watches . (—|—) Lamp ON. First lamp on Pick-up on.

Top view of Pick - up

Button to select Pick - up mode

Acoustical pick-up. First lamp on. (for quartz 32, kHz)

Push once, inductive pick-up . Second lamp on. For stepper motor (1 - 60 cycles)

Push twice, capacitive pick-up. Third lamp on. For LCD watches with 32 kHz and 4.19 mHz

Measuring pad. Lay watch onto pad, pin in center makes contact to receive acoustical signals. Black pad receives inductive and capacitive signals

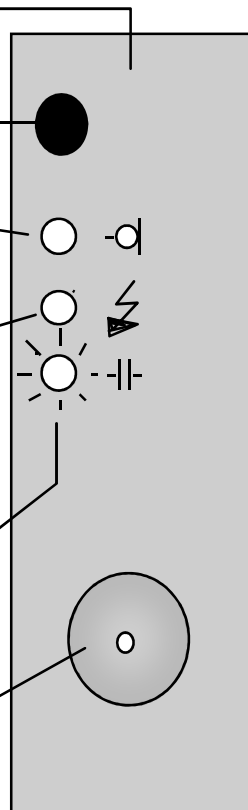

1. Place watch onto measuring pad of the Pick-up
2. Push button twice to select pick-up capacitive mode for LCD watch.
3. If necessary find best position on pad indicated by blinking lamp.
4. Push AUTO, MAN, or FREQ on B 300, the measured result will then be displayed automatically.
5. Push button DIAG if recording on paper is desired.
6. Adjust resolution by RESOL to desired value. Normal scale factor for quartz watches is 100. Only effective if recording on paper.
7. Adjust measuring time interval by TIME to the desired value. Long duration is needed to check the watches of inhibitus type.

TEST OF QUARTZ CRYSTAL WATCHES (ANALOG TYPE)

Top view of Pick - up

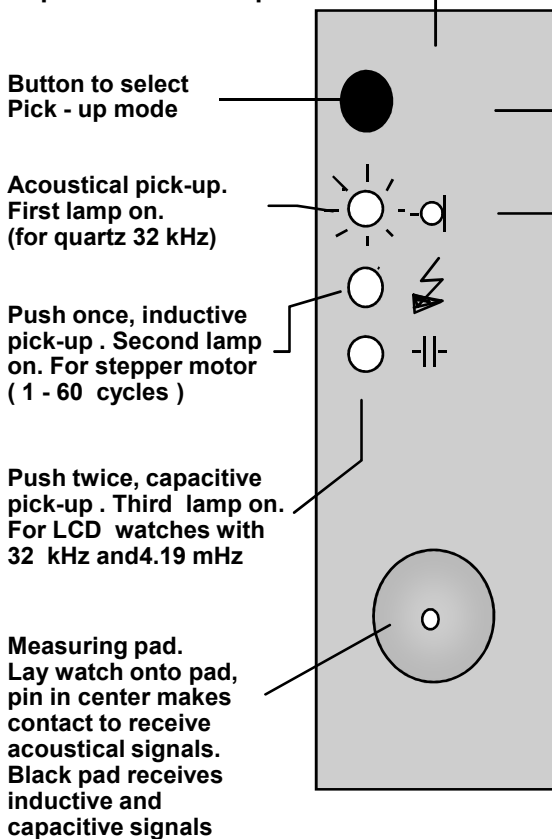

A. Acoustic measurement by quartz frequency

Preset the machine for recording quartz watches. (→□←) Lamp ON First lamp on Pick-up on.

1. Place watch onto measuring pad of the Pick- up
2. Push button to select acoustical Pick- up mode to test the quartz- frequency of the watch.
3. If necessary, find best position on pad indicated by blinking lamp.
4. Push **AUTO**, or **FREQ** on B 300, the measured result will then be displayed automatically.
5. Push button **DIAG** if recording on paper is desired.
6. Adjust resolution by **RESOL** to desired value. Normal scale factor for quartz watches is 100. Only effective if recording on paper.
7. Adjust measuring time interval by **TIME** to the desired value. Long duration is needed to check the watches of inhibitus type.

B. Measure by inductivity of the stepper motor. Key test for watches with inhibition.

1. Same as above
2. Push button to select inductive pick- up mode until lamp  light is on.
3. Same as above
4. Same as above
5. Same as above
6. Same as above
7. Same as above

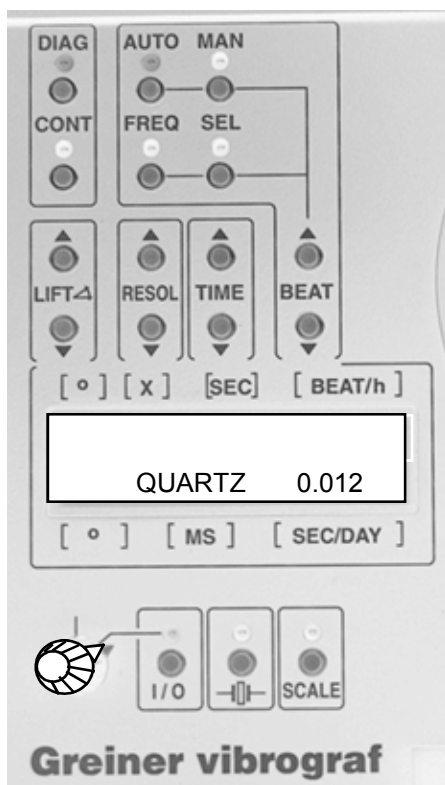

ALPHANUMERIC PRINT

The indicated results of the display on the B 300 can be printed in alphanumeric form on the paper.
This enables you to use the paper as a documentary for your files or records for the customer.

Procedure:

Simply push and hold button *CONT* for 2 seconds.
The recording of dots will be stopped while the alphanumeric data is printed.

Alphanumeric print

The printed values are always the actual values on the display.
Scale disk: The lines on the disk must be adjusted to the diagram.

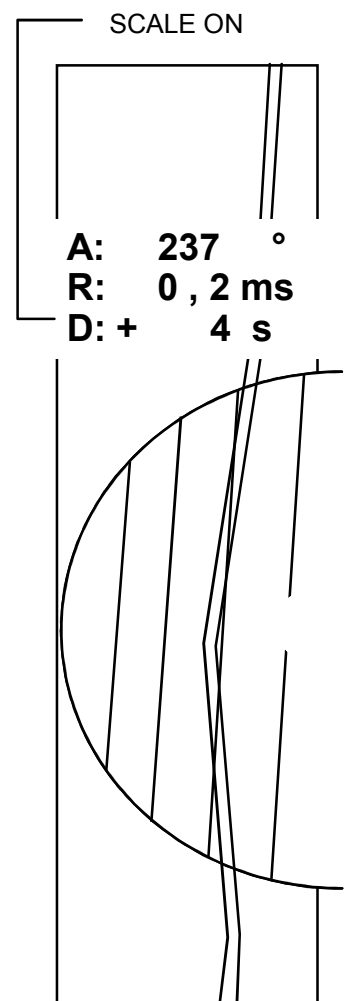
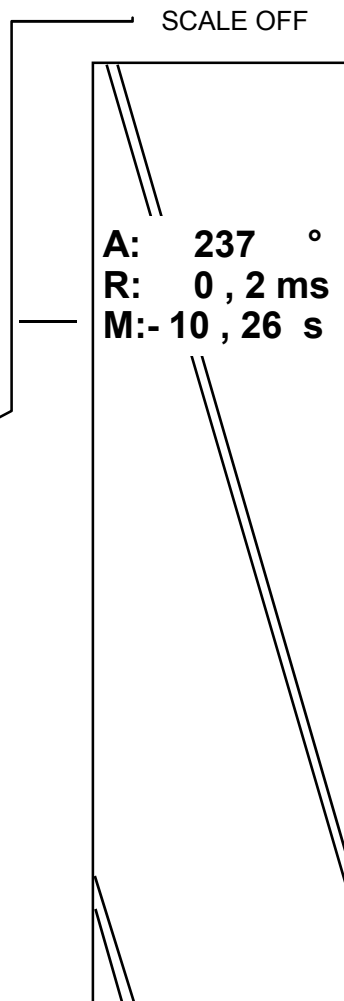
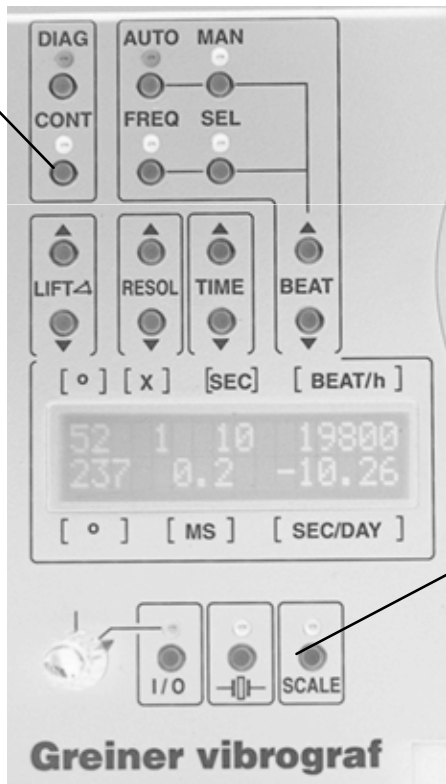

Important:

The number of decimals of time deviation on the display and for result printing depends of the setting by Resolution (x).
See page 13 (technical data).

INSERT PAPER ROLL

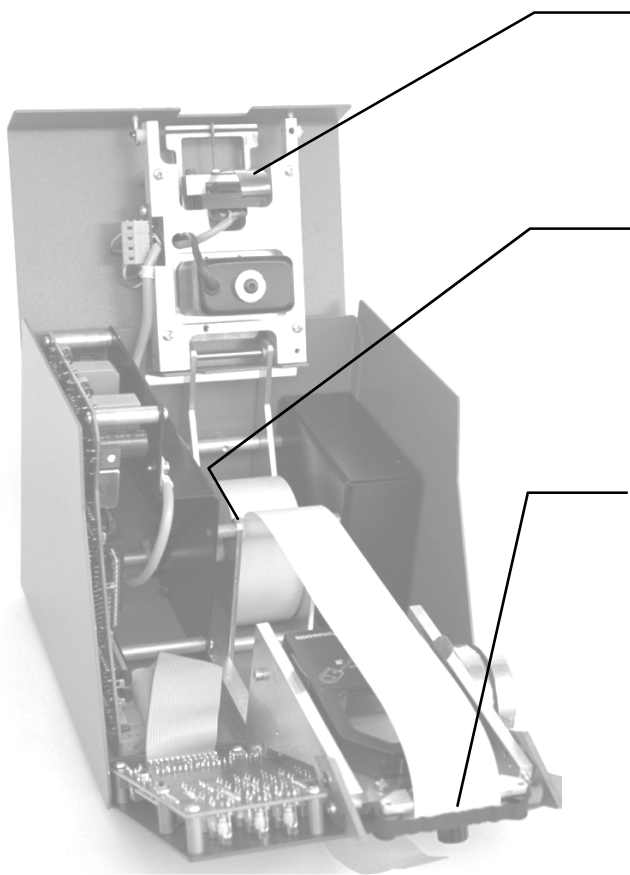

The spring blade will push the paper against the gliding roller by closing the cover. This is to keep the paper stretched while recording.

Pass the paper over the gliding roller.

B 300 requires 36 mm width paper, available from your Greiner vibrograf dealer.

Thread the paper between ink ribbon and anvil cylinder.

Now tilt the frontplate slowly back, so that the paper can curl back by itself. If necessary, help to tighten the paper by rolling back the excessive paper.

Now close the upper cover. Make sure it snaps in correctly.

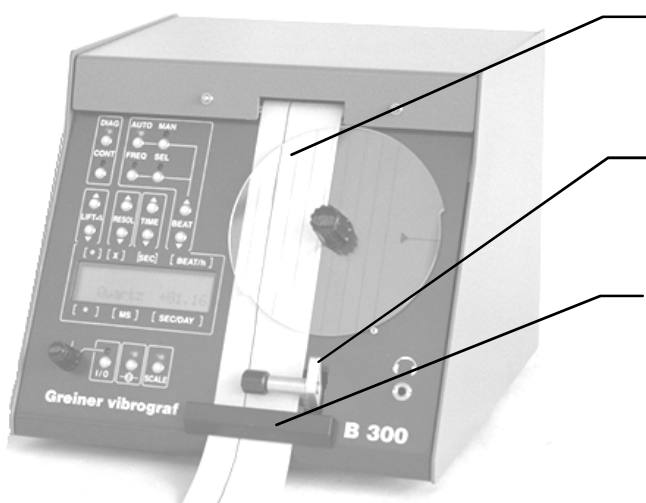

Pass the paper under the index scale.

Lift the pressure roller and insert the paper.

Pull paper under the tear - off bar.

CHANGE INK ROLL CASSETTE

Important : The quality of the diagram is only guaranteed by using genuine ink roll cassettes by GREINER.

Removal of the cassette

1. Open cover and tilt front plate forward.
2. Release the blade spring on the left side of the cassette and remove it.

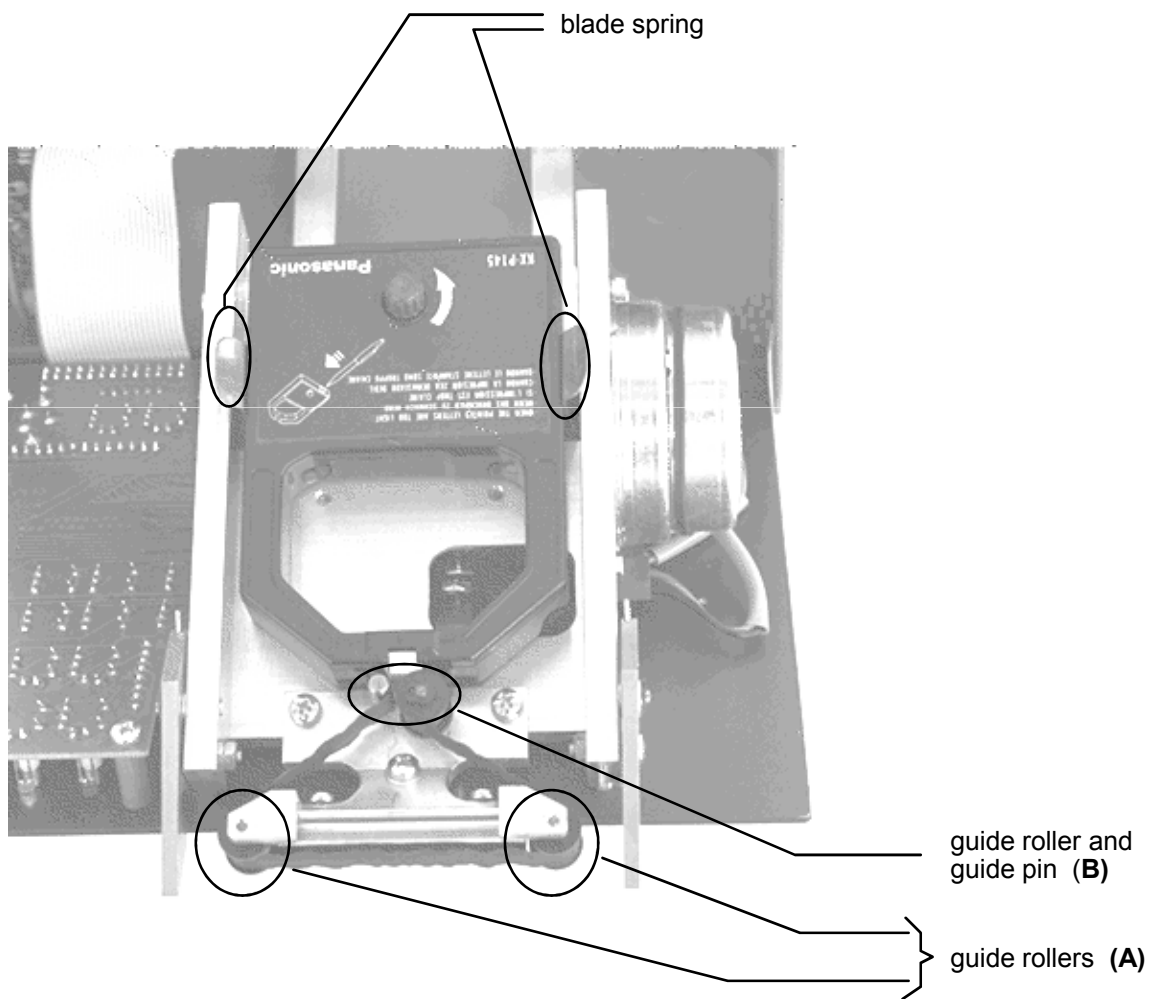

Mount new cassette

1. Pull ink ribbon approx. 8 cm (3 inch) out of the cassette.
2. Thread the extending ink ribbon loop around the guide rollers (A) and between the the guide roller and the guide pin (B) as shown in the picture.
3. Push cassette into its holder until the blade-springs snap.
In case the drive shaft under the cassette does not engage properly, remove the cassette 2 cm and twist the knob on the cassette ccw until it does.

TECHNICAL DATA

The selectable values for :

Beat selection
Lift angle
Resolution
Time

Standard beat values :
adjustable with button **(MAN)**
or, on **AUTO MODE**
if a watch signal is present.

36 000
28 800
21 600
19 800
18 000
16 200
14 400
12 000
10 800
9 000
7 200
3 600

Beat values :
Adjustable by the push button (SEL)

If the light **(SEL)** is on,
all the Beat values

between **3 590 und 36 100**

can be adjusted by the button **(SEL)**

TIME : 2 sec.
4 sec.
10 sec.
20 sec.
60 sec.

RESOL :
for mechanical watches :
No zeros are displayed in front
of the result.

Selectable values:
on

Display : Factor : Result s/d :

0.5	=	1	±	XX
1	=	2	±	XX
2	=	4	±	XX.X
4	=	8	±	XX.X
10	=	20	±	XX.XX
50	=	100	±	XX.XX

0.5 *	=	1	±	XX.XX
1 *	=	2	±	XX.XX
2 *	=	4	±	XX.XX
4 *	=	8	±	XX.XX
10 *	=	20	±	XX.XX
50 *	=	100	±	XX.XX

RESOL:
If Quartz mode is selected:

Selectable values:
on

Display : Factor : Result s/d :

0.5	=	1	±	XX.XX
1	=	2	±	XX.XX
2	=	4	±	XX.XX
4	=	8	±	XX.XX
10	=	20	±	XX.XX
50	=	100	±	XX.XX

Lift angle : 30 ° bis 70 °

Precision of B 300

Quartz : f = 9.216 MHz (tk = ± 1ppm bei 0 - 80 °)

Calibration : with DCF77 radio clock
< ± 0.01 s/d over several hours

COMPUTER CONNECTION (RS- 232)

The back side of B 300 is equipped with a 9 pin (RS -232) serial interface for computer connection.

Baud-rate	4800
Total bits	8
Stop bits	1
Parity	no

Connection cable between B 300 and computer :

Use a direct standard cable (COM 1 - B 300)

Current protocol : Send (upper case o and return) " O Return "

(actual display:)

B 300 returns: Nummer :
Vorwahlen : $\overline{H}\overline{W} = \overline{5}2$, MZ = 2, SZ = 21600
Messwerte : A = 283, R = 0.2, M = +4

Software available: B300COMM.EXE

HELP

Informations on display:

Informations or error messages on display are selfexplanatory.

B 300 is out of operation:

Switch off main power and wait 10 seconds before switching on again.
This will reset the machine and sets all internal values back to initial setting.

Checking if microprocessor is in normal operation.

Check if the run lamp is blinking.

Run lamp

